

# Product Data Sheet

## NPS Dual Sump Station - KSB Amadrainer Pumps

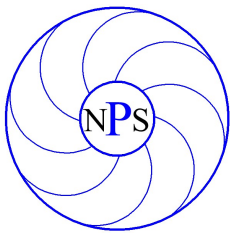

- Chamber designed for the installer and client.
- Unique internal water supply for commissioning and servicing - no more hose pipes!!
- No special tools required to install
- Can use any standard 450mm inspection chamber lid and frame
- Built in 450mm riser - can be trimmed down or extended using standard 450mm risers.

# Product Data Sheet

## NPS Dual Sump Station - KSB Pumps

### Sump Station Specifications:

Chamber Material	MDPE
Chamber Max Volume	240 Litres
Volume Below Inlets	150 Litres
Fixed Inlet bosses	4 off at 90 degree orientation
Isolation Valve	single union double seal EDPM ball valve
None return valve	Quite operation EDPM swing check valve
Cable Duct (reversible)	40mm solvent weld adaptor/40mm high pressure PVC
Discharge Connection	1.5" BSP male 16 Bar (optional 40mm solvent weld waste adaptor supplied)
Internal Pipework and fittings	All manufactured to EN1452-2/3, ISO161/1, BS21, DIN2999, ISO7 - Note threaded fittings are rated at 12 Bar.
Pumps	2 off - KSB 301 Amadrainer Pumps
Riser/Lid	Clark Drain CD452 driveway lid 35KN load
Float switch bracket	Full length aluminium float switch slide for full chamber depth adjustment.
Inlet seal	1 x 110mm dia EDPM tank gasket
Optional - NPS unique internal water supply	

# Product Data Sheet

## NPS Dual Sump Station - KSB Pumps

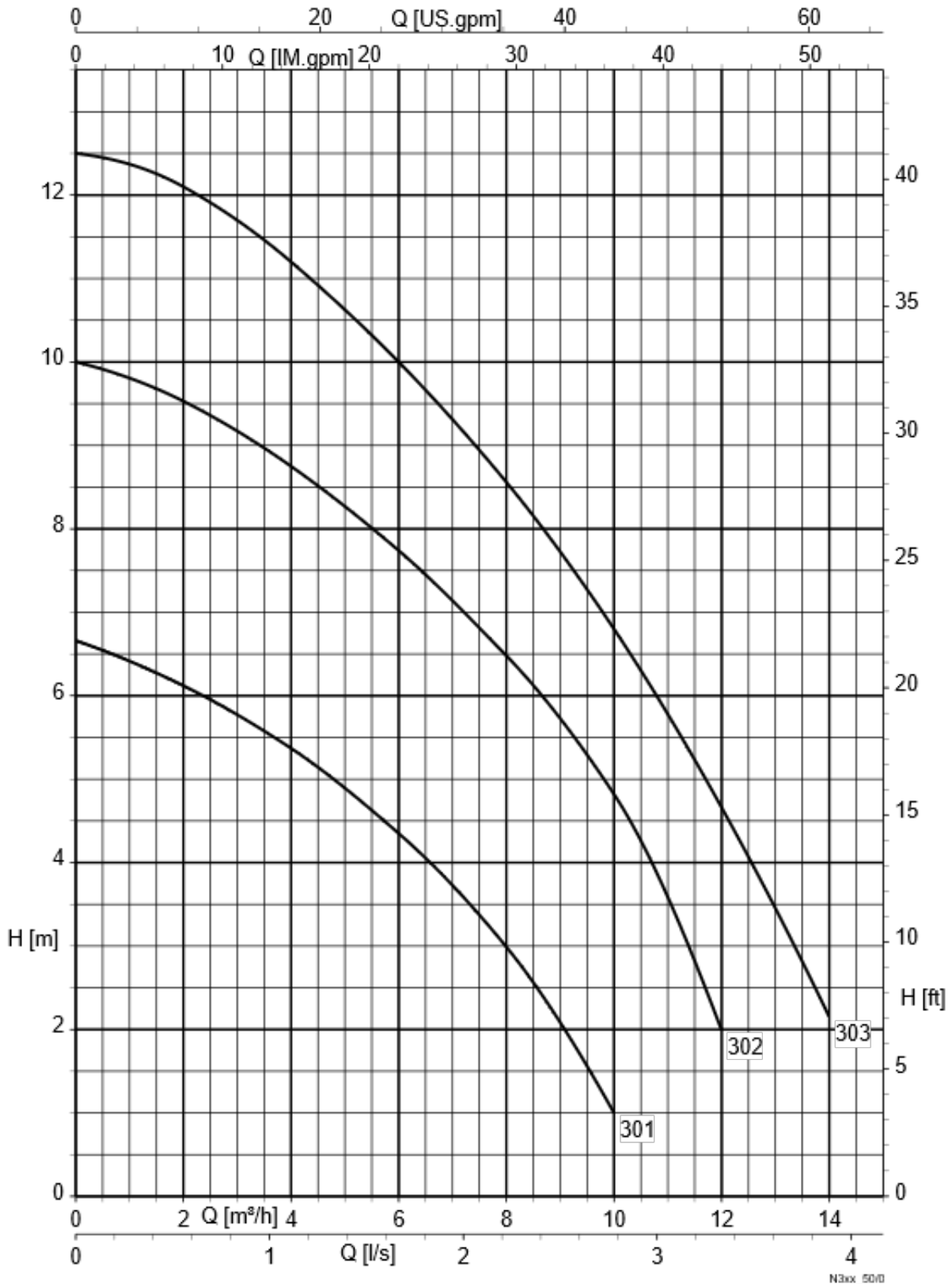

# Product Data Sheet

## NPS Dual Sump Station - KSB Pumps

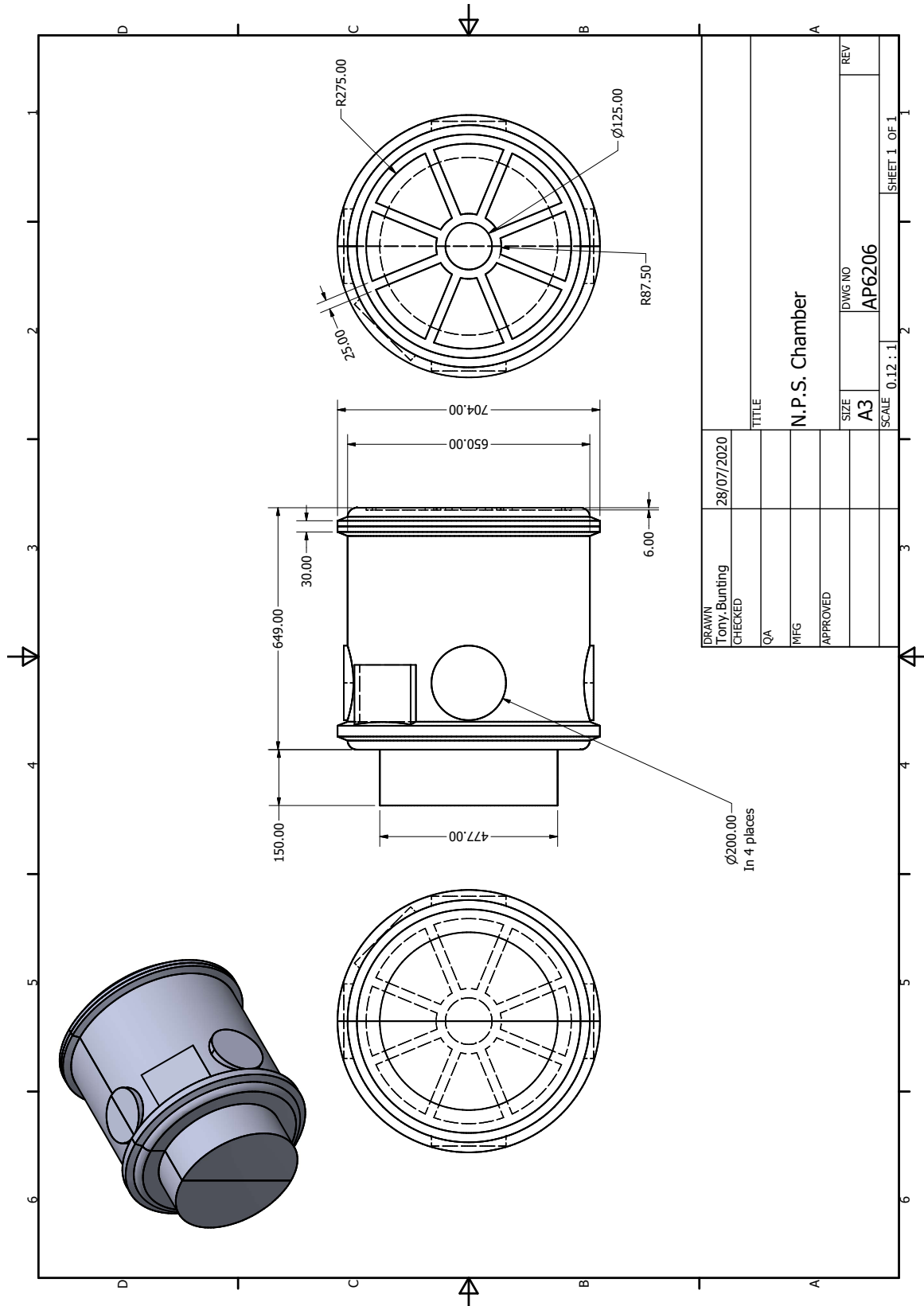

# Product Data Sheet

## NPS Dual Sump Station - KSB Pumps

### Installation Guideline.

Please note that the following information is for guidance only and it is the installers responsibility to ensure that the installation is in accordance with current building regulations and that all relevant site conditions are taken in to consideration.

Our chambers are manufactured from MDPE. The installer must ensure that the chambers are not installed too deep into the ground. The top of the chamber riser must be in line with the structural slab level (SSL) or above. If the chamber is buried too deep, rising water tables may cause the chamber to collapse. Subsequently, the chamber should be stood on a level concrete base and surrounded by a pre formed structural concrete sump. Refer to our technical drawing 101220202-1 for suggested detail.

1. The chamber must be installed in an accessible location for future maintenance.
2. A reinforced, pre formed concrete sump should be created to to locate the sump chamber into. It must be water proofed prior to installing the chamber to prevent water penetration and unnecessary hydro static pressure being exerted on the chamber walls. Ensure the sump is large enough to fit the chamber plus make all necessary connections. A structural Engineer should be consulted on the design to ensure the pre cast sump is capable of withstanding ground and water loads.
3. Make the inlet connection/s. If using the supplied 110mm tank gasket for modular drainage or to create an inlet for perimeter drains drill a 118mm dia hole. It is acceptable to cut other inlet holes into the wall of the chamber either at the top or into the round bosses on the chamber wall.
4. Fit the discharge part of the manifold into the chamber via the pre drilled hole and secure using the lock nuts.
5. Screw the uptake parts of the manifold in to the pumps ensuring the non return valve (NRV) is fitted to the pump first. It may be necessary to use PTFE tape on the threaded connections.
6. Using the unions on the up take pipes, connect to the main part of the installed discharge pipe. Do not use PTFE tape on the unions. The rubber 'O' ring seal will make the joint water tight.
7. Check the orientation of the pumps and that the float switches can operate freely from obstructions.

# Product Data Sheet

## NPS Dual Sump Station - KSB Pumps

8. If installing a twin pump station, ensure that one pump float switch cable is 10mm longer than the other. This will ensure that the shortest cable is the primary pump. If supplied with KSB 300 series pumps, we have preset one pump as the primary pump.
9. Fit the cable duct connector. It is reversible for either solvent weld waste or high pressure PVC.
10. When pulling the pump cables through the cable duct, ensure that sufficient cable is left inside the chamber, to enable the pumps to be lifted out. Tie wrap securely excess cable out of the way of the float switches.
11. The discharge is a 1/1/2" BSP male thread. We also supply an optional 40mm solvent weld waste connector. We recommend that high pressure 10 bar PVC pipe is used for the discharge. No matter which pipe you choose, you MUST use high pressure adhesive (cement) for the connections.
12. When all connections are made and checked, cast in the chamber with concrete. A wet mix may cause the chamber to float. Backfilling in stages is recommended.
13. Our chamber has a built in 450mm riser. This can be trimmed down to suit the lid to ensure an exact level to the finished floor (FFL). If by chance a mistake has been made the riser needs to be extended slightly, a standard 450mm inspection chamber riser such as Osma 4D975 can be fitted with the rubber seal being mated to our chamber.
14. A suitably qualified person in accordance with IEE regulations should make the pump, alarm, pump controller and battery back up electrical connections using the information available. We supply suggested wiring diagrams layouts for different pump set ups.
15. Using a clean water supply (or the optional NPS internal water supply) fill the chamber and test that both pumps work correctly and that the float switches operate freely. If a high level alarm has been fitted, test that it works at the correct level. Adjust the float switch height as necessary.